

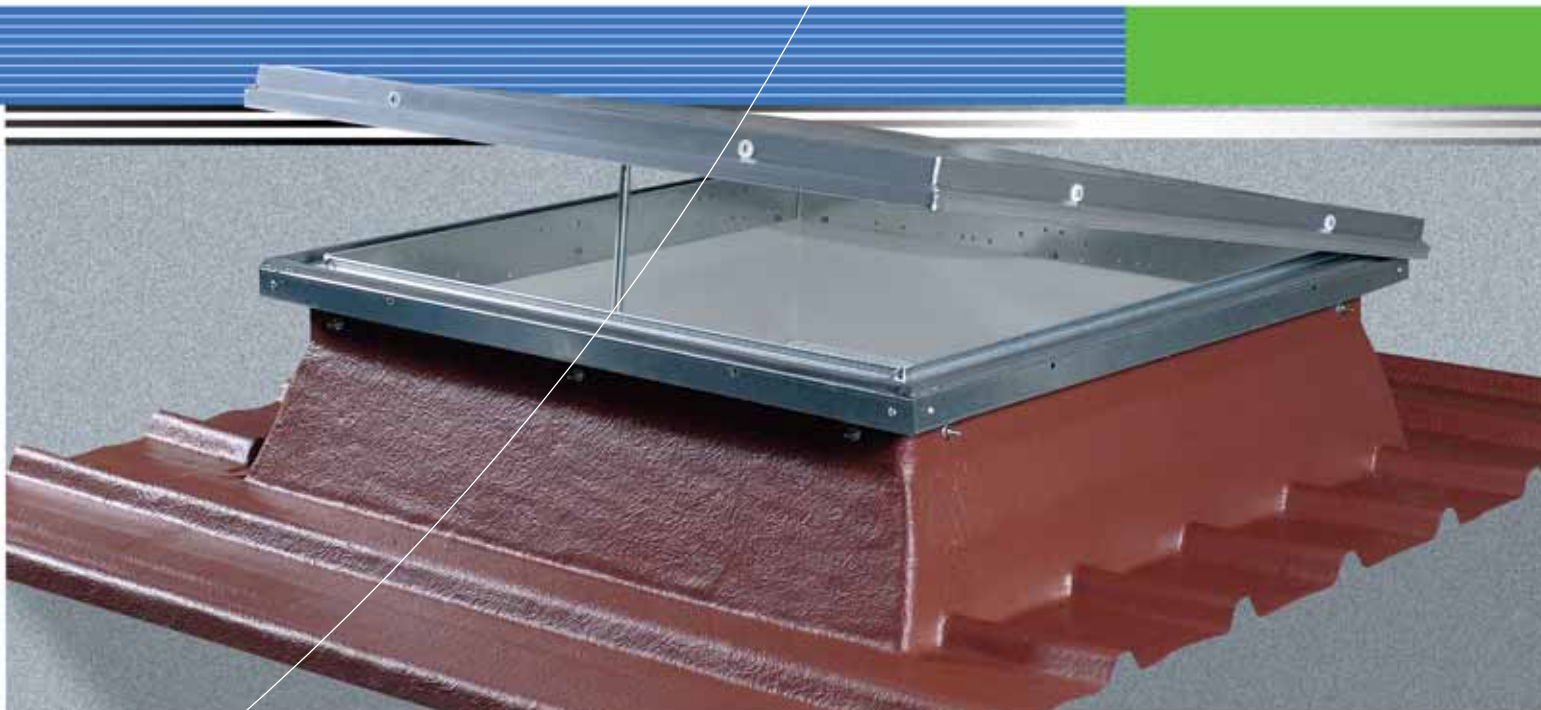

NATURAL VENTILATION / NATURAL DAYLIGHTING

ROOF AÉRATION®



SKYDÔME®
La sécurité en toute clarté

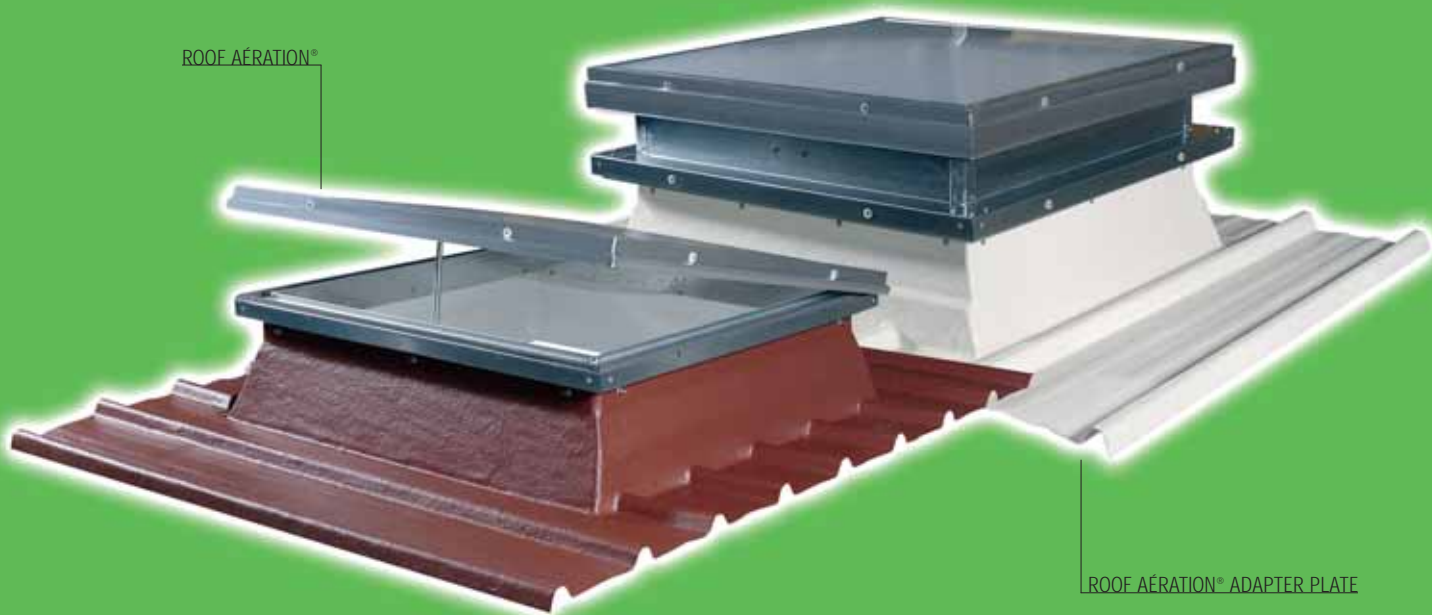

ROOF AÉRATION® is a unit designed to provide static ventilation and to allow natural daylight into a building. It is used on sheeted roof on all types of buildings:

- Public access buildings
- Industrial buildings
- Commercial buildings, offices
- Residential buildings

SKYDÔME® has moulds for bases adapted to the main sheeted roof profiles present on the market.

NATURAL VENTILATION / NATURAL DAYLIGHTING

ROOF AÉRATION®



1

ADVANTAGES

In the open position, a **ROOF AÉRATION®** unit allows air passage to a height of 300 mm.

ROOF AÉRATION® can be opened by the following methods:

- Manual opening: by 250 mm continuous worm screw, operated by a winding handle.
- Electric: by a 300 mm electric cylinder linked to the standard electricity circuit (220/240V).
- Pneumatic: by a 300 mm pneumatic cylinder linked to the pneumatic network of the installation.

A wide range of polyester bases: **SKYDÔME®** has moulds for bases adapted to the main sheeted roof profiles present on the market. **ROOF AÉRATION®** is assembled on the polyester base. The dimensions and references list of the bases, adapted to each profile, is summarized in the "Bases" brochures.

Colour finish: as an option, **ROOF AÉRATION®** can be delivered on a painted base in one of the main RAL colours.



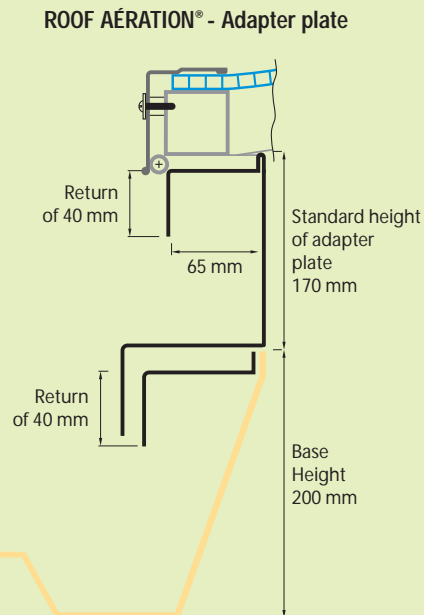
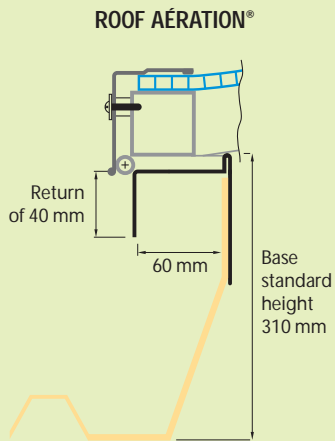

2

COMPOSITION

ROOF AÉRATION® is composed of:

- **Base + box:**

- A polyester **base** conform to the norm NFP 37.417, with an angled kerb height of 310 mm. The top part of the base is composed of a 60mm part allowing the rain water evacuation.
- A **box** in galvanised steel sheet fixed on the polyester unit. It integrates the opening frame and the different opening systems.

- **Base + adapter plate:**

- A polyester **base** conform to the norm NFP 37.417, with an angled kerb height of 200 mm. The top part of the base is composed of a 76mm part allowing the rain water evacuation. It also has a galvanised steel edge on which the adapter plate is installed and fixed.
- An **AIRDÔME®** adapter plate described in the "AIRDÔME®" brochure.

This two parts version can be proposed in case of difficulties of handling the units on the roof.

- **A tubular opening frame in galvanised steel:** this is hinged to the kerb and the opening is determined by the length of the cylinder motor or of the continuous worm screw.

- **Glazing: ROOF AÉRATION®**

As standard either 10 mm reinforced, structured opalescent polycarbonate sheet (PCA) (tested to 1200 joules) or PMMA double domes. The following options are also available: 10 and 16 mm polycarbonate, triple- or quadruple-walled structured polycarbonate sheet for better thermal resistance or an aluminium cover. Single dome or pyramid dome available on request. All PCA glazing has anti U.V. treatment.

To choose the type of glazing required, see the table entitled "Glazing - Performance".

The positioning of the glazing and the design of our units reduce the build-up of condensation as air circulates between the frame and the kerb.

- **Aluminium beading frame:** fixed by stainless steel screws and nylon washers. This holds the glazing in place and protects edges from lateral impact. It also improves the aesthetic appeal of the ROOF AÉRATION®.

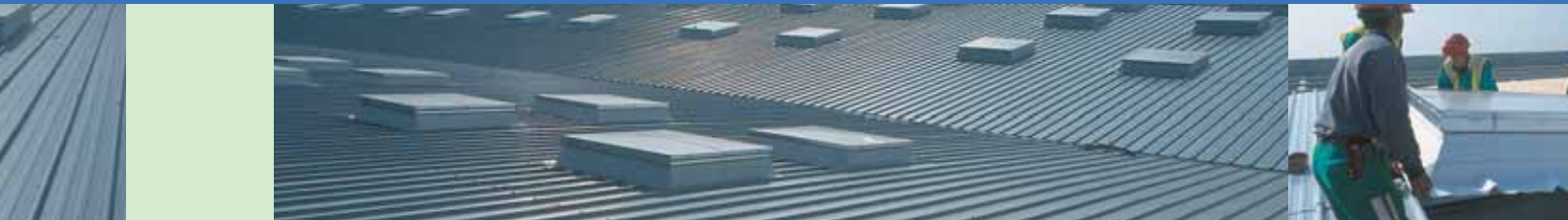

Manual opening and closing of the **ROOF AÉRATION®** :

The continuous worm screw is activated by the movement of a winding handle, available in different lengths according to the height of the ceiling.

Ceiling from 2 m to 2,50 m = winding handle 1,50 m long

Ceiling from 2,50 m to 3 m = winding handle 2 m long

Ceiling from 3 m to 3,50 m = winding handle 2,50 m long

Ceiling from 3,50 m to 4 m = winding handle 3 m long

Ceiling from 4 m to 4,50 m = winding handle 3,50 m long

Electric opening and closing of the **ROOF AÉRATION®** :

The opening and closing of the unit is operated by an electric cylinder connected to the 220/240 volt supply. This cylinder is activated by a 3 position electric interrupter, available as an option.

Pneumatic opening and closing of the **ROOF AÉRATION®** :

A double action pneumatic cylinder (ref. XAJ100), powered by the existing pneumatic network, operates the opening and closing mechanism.



TYPE OF GLAZING	THERMAL TRANSMISSION U (W/m ² °C)	LIGHT TRANSMISSION (%)	FIRE CLASSIFICATION	ACOUSTIC (db (A))
Simple Dome PMMA (Polymetacrylate methyle) - Opal	5.2	82	M4	12
Double Dome PMMA (Polymetacrylate methyle)	3.1	76	M4	19
10 mm structured polycarbonate - Clear	3.1	85	M2 and/or M1	17
10 mm structured polycarbonate - Opal	3.1	62	M2 and/or M1	17
10 mm structured polycarbonate - Venetian	3.1	33	M2 and/or M1	17
10 mm structured polycarbonate - Comfort	3.1	55	M2 and/or M1	17
10 mm structured polycarbonate - 4-walled opal	2.5	55	M2 and/or M1	17
16 mm structured polycarbonate - Clear	2.3	79	M2 and/or M1	21
16 mm structured polycarbonate - Opal	2.3	57	M2 and/or M1	21
16 mm structured polycarbonate - K clear	2	72	M2 and/or M1	21
16 mm structured polycarbonate - K Opal	2	57	M2 and/or M1	21
16 mm structured polycarbonate - K Comfort	2	50	M2 and/or M1	21

For other types of glazing: see the datasheet on Optional Accessories

The non moving parts of **ROOF AÉRATION®** units are guaranteed for ten years (when installed and used in accordance with our specifications). **ROOF AÉRATION®** conforms to regulatory standard NFP 37-418.

ROOF AÉRATION®, with its structured polycarbonate glazing, is approved by the CSTB Avis Technique n° 2/03-1027.

Resistance to upward static load: 1000 pa (1000 N/m²).

Resistance to downward static load: 1500 pa (1500 N/m²).

Fire rating data and 1200 joules test data can be found on our website: www.skydome-axt.com under the heading "Espace Partenaires" (Partner information).

- Grill tested to 1200 joules
- Painted grill tested to 1200 joules
- Domes 1200 joules
- Domes, pyramid domes
- Quadruple-walled PCA10, PCA16, etc
- Aluminium cover 10-20-60
- External base painted in one of the main RAL colours

Options for Adapter plates:

- See Airdôme® brochure
- Adapter plate insulation



Installation should be carried out in accordance with current regulations. Decks should be sound and resistant and should conform to the requirements of current decking standards and of the installation guide. Maximum roof slope: 25°, i.e. 45%. If the slope of the roof is less than 25°, the hinged side of the unit must be parallel to the slope. If the slope of the roof is less than 3° there is no particular requirement.

Fixing: in accordance to the current DTU standards and the norm NFP 37.417, the base is installed on a trimmer-joint. The base has to be fixed on wood, by screwing or bolting, on concrete, by pegging, and on steel, by screwing.

Waterproofing seal:

- through a transverse installation under and above the existing roof, in accordance to the norm NFP 37.417.

Maintenance: glazing must be washed with soapy water. Corrosive products or solvents must not be used.

8 GEOMETRIC DIMENSIONS

DIMENSION OF ROOF OPENING CA x CB* (cm)	LIGHT TRANSMISSION SURFACE (m ²)	ROOF AÉRATION®			
		CH (cm)		CH1 (cm)	
		with domes	with PCA	with domes	with PCA
70 x 100	0.70	58	40	64	46
100 x 100	1.00	58	40	64	46
120 x 120	1.44	60	40	66	46
140 x 140	1.96	63	40	69	46
160 x 160	2.56	68	40	74	46
100 x 150	1.50	58	40	64	46
100 x 200	2.00	58	40	64	46

* CB is the side where the hinges are located (except units 100x150 and 100x200, hinges on side CA, opening to the bottom)

ROOF AÉRATION®

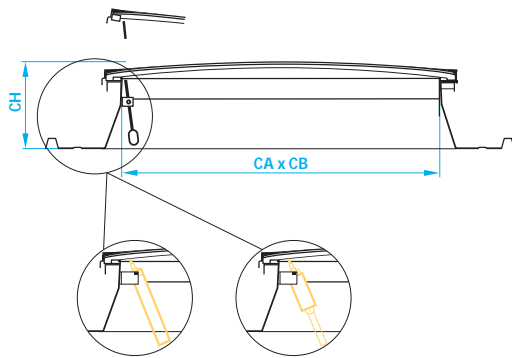

ROOF AÉRATION® ADAPTER PLATE

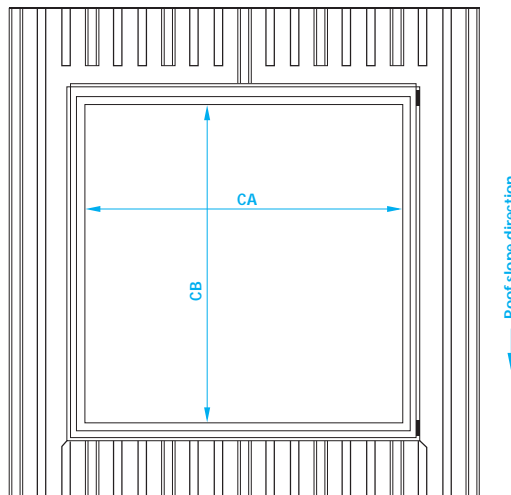
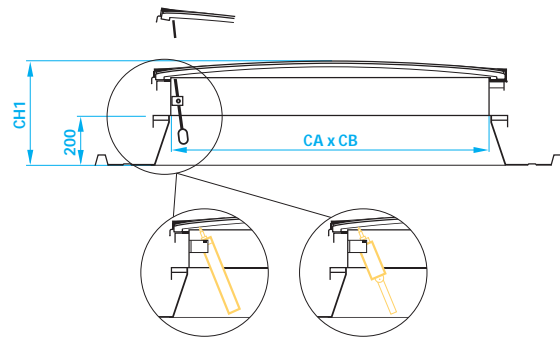

Ref.: Roof Aération® 03/2007 - The manufacturer reserves the right without prior notice to modify the composition of his products. Characteristics provided in this publication derive from data obtained under controlled test conditions. Axter makes no warranties, express or implied, as to the properties and performance under any variations from such conditions in actual construction. DUF-OUR COMMUNICATION